

ACME[®]

TV
PANEL200

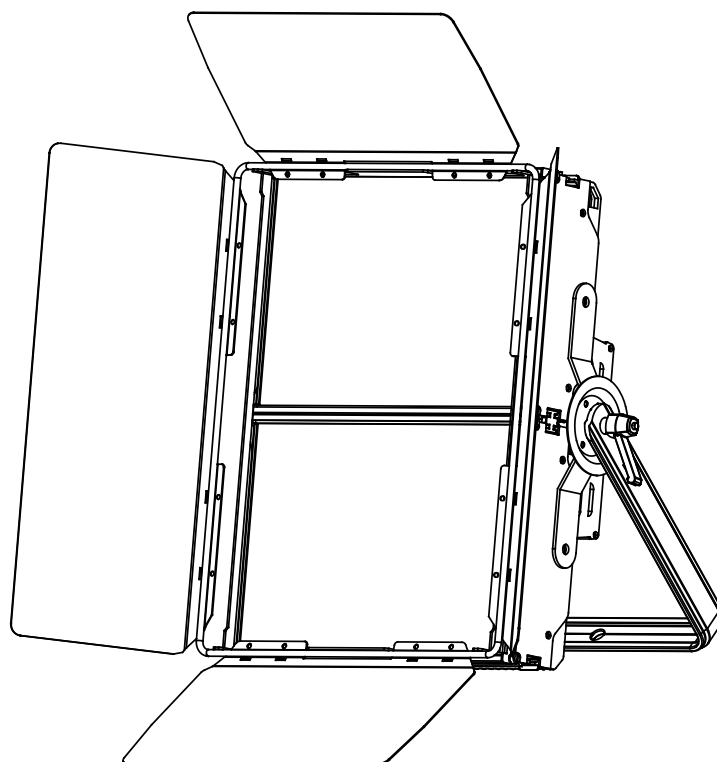

LP-F200 WW

LP-F200 CW

LP-F200 VW

User Manual

Please read the instructions carefully before use

CONTENTS

1. Safety Introductions	2
2. Technical Specifications	3
3. How To Set The Fixture	4
3.1 Control Panel	4
3.2 How to Change the “Remote Phosphor Panel” to Change Color Temperature.....	5
3.3 Main Function.....	6
4. How To Control The Unit.....	9
4.1 Master/Slave Function.....	9
4.2 DMX Controller	9
4.3. DMX512 Configuration	10
4.4. DMX512 Connections	11
5. Troubleshooting.....	12
6. Fixture Cleaning.....	13

1. Safety Introductions



WARNING

Please read the instructions carefully which includes important information about the installation, operation and maintenance.

Please keep this User Manual for future consultation. If you sell the unit to another user, be sure that they also receive this instruction booklet.

- Unpack and check carefully there is no transportation damage before using the unit.
- Before operating, ensure that the voltage and frequency of power supply match the power requirements of the unit.
- It's important to ground the yellow/green conductor to earth in order to avoid electric shock.
- The unit is for indoor use only. Use only in a dry location.
- The unit must be installed in a location with adequate ventilation, at least 50cm from adjacent surfaces. Be sure that no ventilation slots are blocked.
- Disconnect main power before replacement or servicing.
- Make sure there are no flammable materials close to the unit while operating as it is fire hazard.
- Use safety cables when fixing this unit.
- Maximum ambient temperature is T_a : 40 degrees C. DO NOT operate it where the temperature is higher than this.
- Turn off the power and allow about 15 minutes for the unit to cool down before servicing.
- In the event of a serious operating problem, stop using the unit immediately. Never try to repair the unit by yourself. Repairs carried out by unskilled people can lead to damage or malfunction. Please contact the nearest authorized technical assistance center. Always use the same type spare parts.
- DO NOT touch any cables during operation as high voltage may cause electric shock.

Warning:

- To prevent or reduce the risk of electrical shock or fire, do not expose the unit to rain or moisture.
- The housing and lenses must be replaced if they are visibly damaged.

Caution:

There are no user serviceable parts inside the unit. Do not open the housing or attempt any repairs yourself. In the unlikely event your unit may require service, please contact your nearest dealer.

Installation:

The unit should be mounted via its screw holes on the bracket. Always ensure that the unit is firmly fixed to avoid vibration and slipping while operating. Make sure that the structure to which you are attaching the unit is secure and is able to support a weight of 10 times of the unit's weight. Also always use a safety cable that can hold 12 times of the weight of the unit when installing the fixture.

The equipment must be installed by professionals. It must be fixed at a place where is out of the reach of people and no one pass by or under it.

2. Technical Specifications

◇ Power Voltage:	AC 100 ~ 240V, 50/60Hz
◇ Power Consumption:	200W
◇ Light Sources:	CREE LED
◇ Fuse:	T5A
◇ Beam Angle:	120°
◇ Color Temperature:	
WW:	3200 ± 160 K
CW:	5600 ± 280 K
VW:	3200 ~ 5600 K
◇ CRI:	
WW:	≥ 95
CW:	≥ 90
◇ Weight:	11.8Kgs
◇ Dimension:	387 x 275 x 231mm

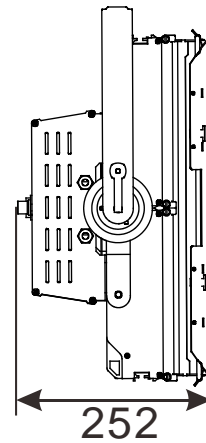
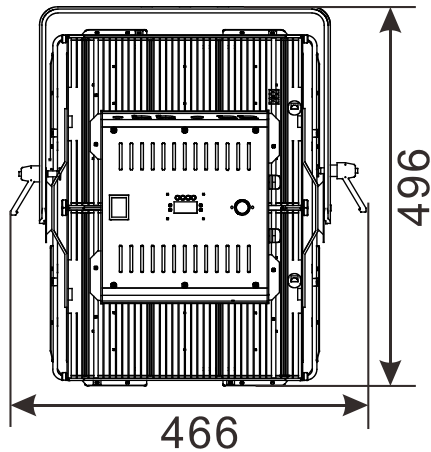

3. How To Set The Fixture

3.1 Control Panel

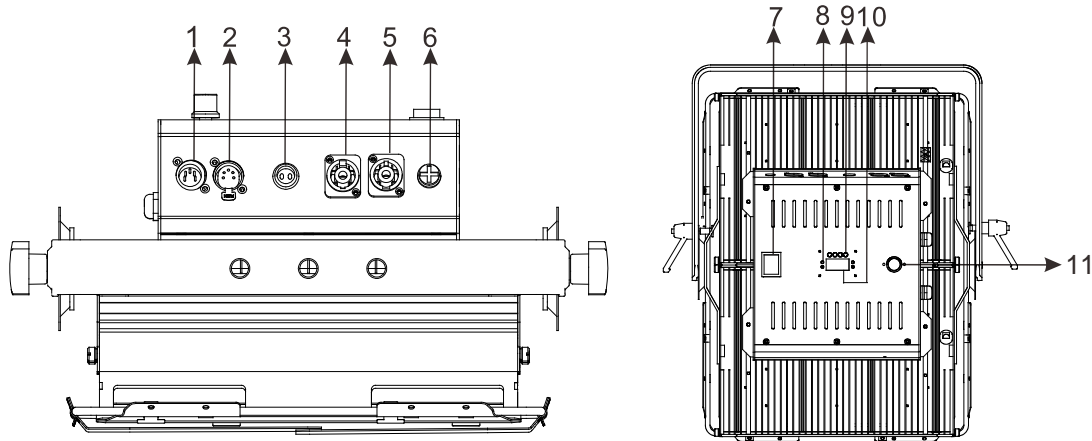

1. **DMX IN** : For DMX 512 link, use 5-pin XLR cable to link the unit to a DMX controller;
2. **DMX OUT**: For DMX 512 link, use 5-pin XLR cable to link to the next unit and output DMX signal;
3. **Battery DC24V Input Socket**: Connects to external battery;
4. **POWER OUT**: Connects to the next unit;
5. **POWER IN**: Connects to mains supply power;
6. **Fuse (T5A)**: To protect the unit from damage of over current;
7. **Power Switch**: Turns On/Off the DC/AC power;
8. **Indicator LED**:

DMX	On	DMX input present
MASTER	On	Master Mode
SLAVE	On	Slave Mode

POWER	On	Power On
--------------	----	----------

9. Button:

MENU	To select the programming functions
DOWN	To go backward in the selected functions
UP	To go forward in the selected functions
ENTER	To confirm the selected functions

10. Display: Shows the various menus and the selected functions;

11. Dimmer Adjust knob: Adjusts the lightness for the unit.

3.2 How to Change the “Remote Phosphor Panel” to Change Color Temperature

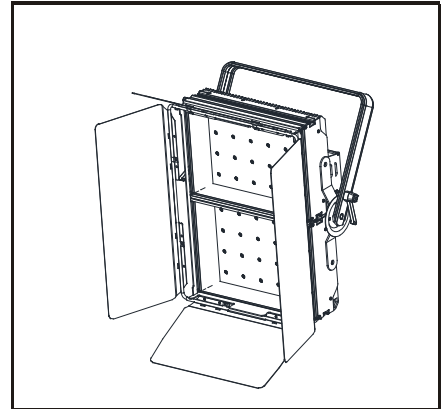
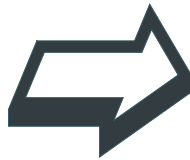
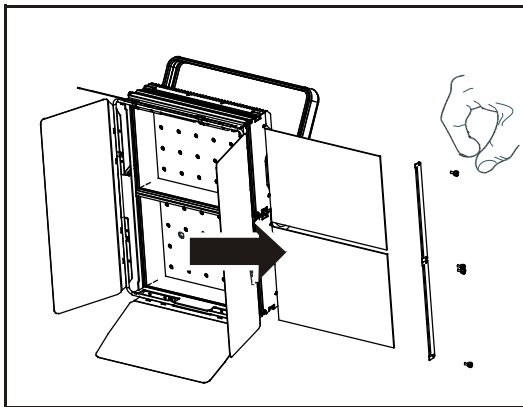

Loosen the screws of the fixture, put out the active frame and remote phosphor panel.

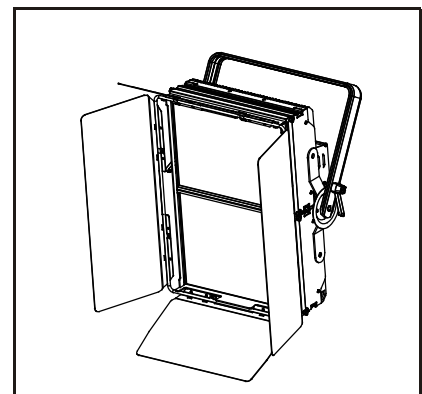
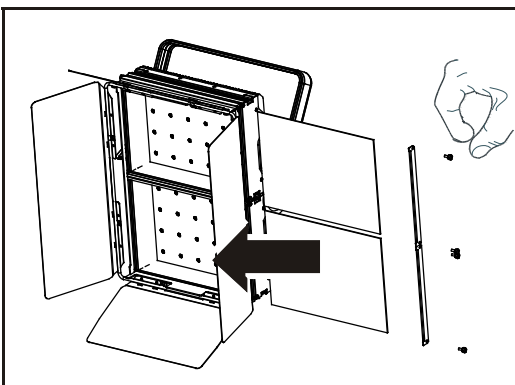

Change another Remote Phosphor Panel to Change Color Temperature, then put on the active frame and tighten the screws.

3.3 Main Function

To select any of the given functions, press the **MENU** button up to the required selection as shown on the display. Select the function with the **ENTER** button and the display will blink. Use the **DOWN/UP** buttons to change the mode. Once the required mode has been selected, press the **ENTER** button to confirm. To go back to the main functions without any changes press the **MENU** button again. Press and hold the **MENU** button for about one second or wait for 7 seconds to exit the current mode.

The main functions are shown below:

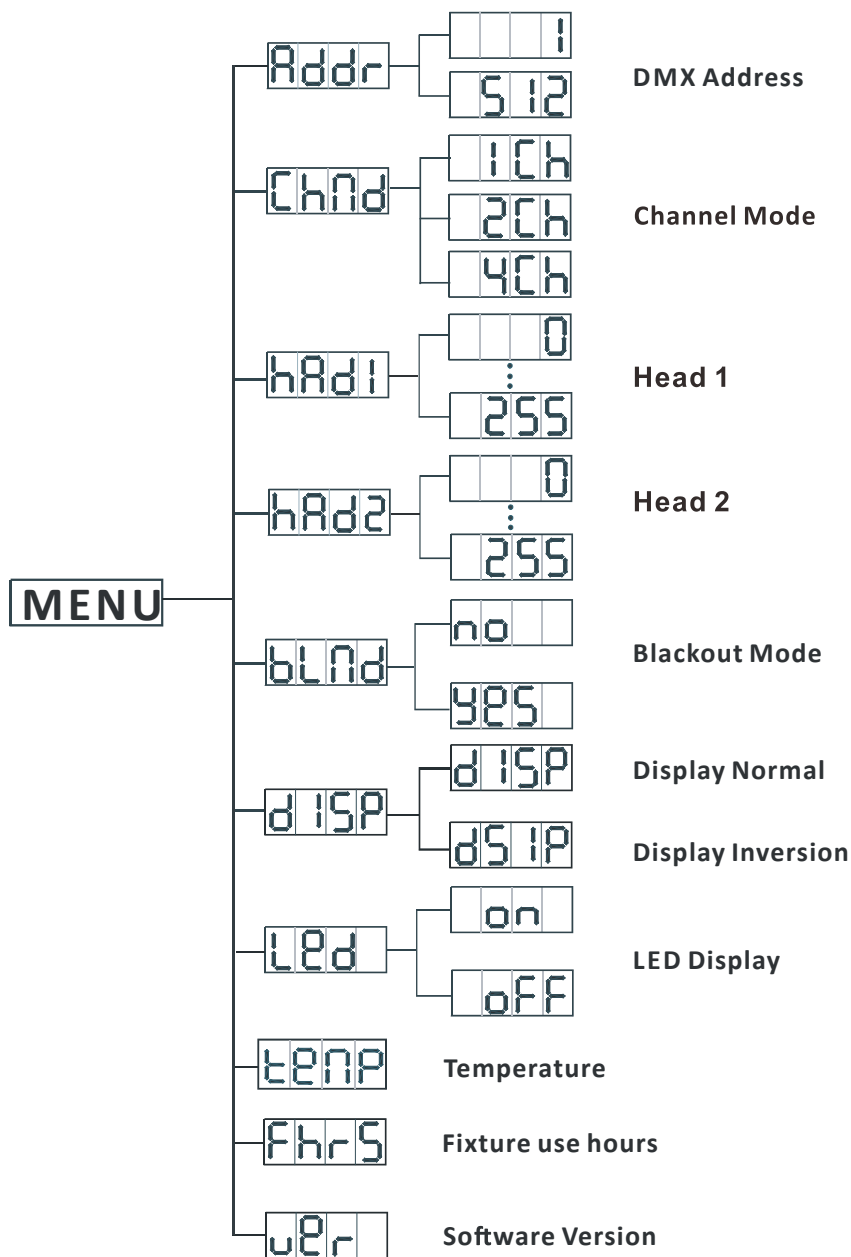

Addr DMX 512 Address

To select **Addr**, press the **ENTER** button to show **DMX ADDRESS** on the display. Use the **DOWN/UP** buttons to adjust the address from **1** to **512**. Once the address has been selected, press the **ENTER** button to setup or automatically exit menu mode without any change after 30 seconds. To go back to the previous functions without any change press the **MENU** button.

ChMd Channel Mode

To select **ChMd**, press the **ENTER** button to show **CHANNEL MODE** on the display. Use the **DOWN/UP** buttons to select **1CH**, **2CH** or **4CH** mode. Once the mode has been selected, press the **ENTER** button to setup or automatically exit menu mode without any change after 30 seconds. To go back to the functions without any change press the **MENU** button.

hAd1 Head 1

To select **hAd1**, press the **ENTER** button to show the **HEAD 1** on the display. Use the **DOWN/UP** button to adjust the value between **0** and **255**, once select press the **ENTER** button to setup or automatically exit menu mode without any change after 30 seconds. To go back to the functions without any change press the **MENU** button.

hAd2 Head 1

To select **hAd2**, press the **ENTER** button to show the **HEAD 2** on the display. Use the **DOWN/UP** button to adjust the value between **0** and **255**, once select press the **ENTER** button to setup or automatically exit menu mode without any change after 30 seconds. To go back to the functions without any change press the **MENU** button.

blMd Blackout Mode

To select **blMd**, press the **ENTER** button to show **BLACKOUT MODE** on the display. Use the

DOWN/UP buttons to select **YES** (blackout) or **NO** (normal) mode. Once the mode has been selected, press the **ENTER** button to setup or automatically exit menu mode without any change after 30 seconds. To go back to the functions without any change press the **MENU** button.

DISP Display Inverse

To select **DISP**, press the **ENTER** button to show **DISPLAY** on the display. Press the **ENTER** button again and it will show the **DISP** (inversion). To go back to the functions without any change press **MENU** button.

LED LED display

To select **LED**, press the **ENTER** button to show **LED** on the display. Use the **DOWN/UP** buttons to select **ON** (LED on) or **OFF** (LED off) mode. Once the mode has been selected, press the **ENTER** button to setup or exit menu mode without any change after 30 seconds. To go back to the functions without any change press **MENU** button again.

TEMP TEMP.

To select the **TEMP**, press the **ENTER** button to show the **TEMP.** on the display and the display will show the temperature of the unit . To go back to the functions without any changes press the **MENU** button again. Hold and press the **MENU** button for one second or wait for one minute to exit the menu mode.

Fhrs Fixture use hours

To select **Fhrs**, press the **ENTER** button to show **FIXTURE USE HOURS** on the display and the display will show the number of working hours of the unit. To go back to the functions press the **MENU** button.

Ver Software Version

To select **uEr**, press the **ENTER** button to show **SOFTWARE VERSION** on the display and the display will show the version of the software of the unit. To go back to the functions press the **MENU** button.

4. How To Control The Unit

You can operate the unit in two ways:

1. By master/slave function
2. By DMX controller

You do not need to turn the unit off when you change the DMX address, the new DMX address setting will take effect immediately.

4.1 Master/Slave Function

By linking the units in master/slave connection, the first unit will be master automatically. You should set the master unit effect via its knobs, then the other units (slave) will lighting as the same.

4.2 DMX Controller

When using a universal DMX controller to control the units, you must set a DMX address from 1 to 512.

Press the **MENU** button up to when **Addr** is showing on the display. Press the **ENTER** button and the display will blink. Use the **DOWN/UP** buttons to change the DMX 512 address. Once the address has been selected, press and hold the **ENTER** button until the display stops blinking or it will store automatically 30 seconds later. To go back to the functions without any change press the **MENU** button again.

If you use please refer to the following diagram to address your DMX512 channel for the first 4 units.

1CH Mode:

			1
--	--	--	---

			2
--	--	--	---

			3
--	--	--	---

			4
--	--	--	---

2CH Mode:

			1
--	--	--	---

			3
--	--	--	---

			5
--	--	--	---

			7
--	--	--	---

4CH Mode:

			1
--	--	--	---

			5
--	--	--	---

			9
--	--	--	---

			13
--	--	--	----

4.3. DMX512 Configuration

1 Channel Mode:

CHANNEL	VALUE	FUNCTIONS
1	0 ~ 255	3600 & 5200 K 0 → 100%

2 Channel Mode:

CHANNEL	VALUE	FUNCTIONS
1	000 ~ 255	3600 K 0 → 100%
2	000 ~ 255	5200 K 0 → 100%

4 Channel Mode:

CHANNEL	VALUE	FUNCTIONS
1	000 ~ 255	DIMMER 0 → 100%
2	000 ~ 255	3600 K 0 → 100%
3	000 ~ 255	5200 K 0 → 100%
	000 ~ 007 008 ~ 015 016 ~ 131 132 ~ 139	STROBE Off Open Strobe: Slow → Fast open

4	140 ~ 181	Slow Open Fast Close
	182 ~ 189	Open
	190 ~ 231	Slow Close Fast Open
	232 ~ 239	Open
	240 ~ 247	Random Strobe
	248 ~ 255	Open

4.4. DMX512 Connections

The DMX512 is widely used in intelligent lighting control, with a maximum of 512 channels.

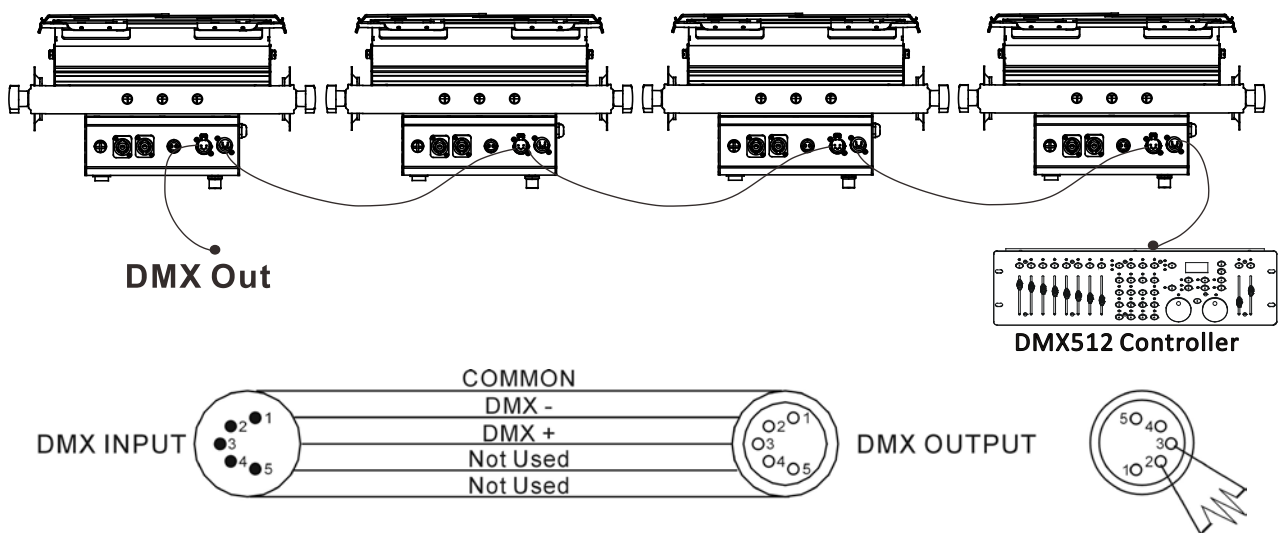

1. At last unit, the DMX cable has to be terminated with a terminator. Solder a 120-ohm 1/4W resistor between pin 2(DMX-) and pin 3(DMX+) into a 3-pin XLR-plug and plug it in the DMX-output of the last unit.
2. Connect the unit together in a “daisy chain” by XLR plug cable from the output of the unit to the input of the next unit. The cable cannot be branched or split to a “Y” cable. DMX 512 is a very high-speed signal. Inadequate or damaged cables, soldered joints or corroded connectors can easily distort the signal and shut down the system.
3. The DMX output and input connectors are pass-through to maintain the DMX circuit, when one of the units’ power is disconnected.
4. Each lighting unit needs to have a DMX address to receive the data by the controller. The address number is between 0-511 (usually 0 & 1 are equal to 1).

5. The end of the DMX 512 system should be terminated to reduce signal errors.
6. 3 pin XLR connectors are more popular than 5 pins XLR.
3 pin XLR: Pin 1: GND, Pin 2: Negative signal (-), Pin 3: Positive signal (+)
5 pin XLR: Pin 1: GND, Pin 2: Negative signal (-), Pin 3: Positive signal (+), Pin4, Pin5 not used.

5. Troubleshooting

Following are a few common problems that may occur during operation. Here are some suggestions for easy troubleshooting:

A. The fixture does not work, no light

1. Check the connection of power and main fuse.
2. Measure the mains voltage on the main connector.

B. Not responding to DMX controller

1. DMX LED should be on. If not, check DMX connectors, cables to see if link properly.
2. If the DMX LED is on and no response to the channel, check the address settings and DMX polarity.
3. If you have intermittent DMX signal problems, check the pins on connectors or on PCB of the fixture or the previous one.
4. Try to use another DMX controller.
5. Check if the DMX cables run near or run alongside to high voltage cables that may cause damage or interference to DMX interface circuit.

C. One of the channels is not working well

1. The stepper motor might be damaged or the cable connected to the PCB is broken.
2. The motor's drive IC on the PCB might be out of condition.

6. Fixture Cleaning

Cleaning must be carried out periodically to optimize light output. Cleaning frequency depends on the environment in which the fixture operates: moist, smoky or particularly dirty surroundings can cause a greater accumulation of dirt on the fixture.

- Clean with soft cloth using normal glass cleaning fluid or mild soapy water.
- Always dry the parts carefully.
- Clean the external optics at least every 30 days.

Declaration of Conformity

We declare that our products (lighting equipment) comply with the following specification and bears CE mark in accordance with the provision of the Electromagnetic Compatibility (EMC) Directive 89/336/EEC.

EN55103-1: 2009 ; EN55103-2: 2009; EN62471: 2008;
EN61000-3-2: 2006 + A1:2009 + A2:2009; EN61000-3-3: 2008.

&

Harmonized Standard

EN 60598-1:2008 + All:2009; EN 60598-2-17:1989 + A2:1991; EN 62471:2008;
EN 62493: 2010
Safety of household and similar electrical appliances
Part 1: General requirements

Innovation, Quality, Performance